



## Owner's Manual Refrigerated Compressed Air Dryers Model F-75

Read carefully before attempting to assemble, install, operate or maintain the product described. Protect yourself and others by observing all safety information. Failure to comply with instructions could result in personal injury and/or property damage. Retain instructions for future reference.

**WARNING:** Air treated by this equipment is not suitable for breathing without further purification. Refer to O.S.H.A. standards for the requirements for breathing quality air.



Figure 1 - F-75

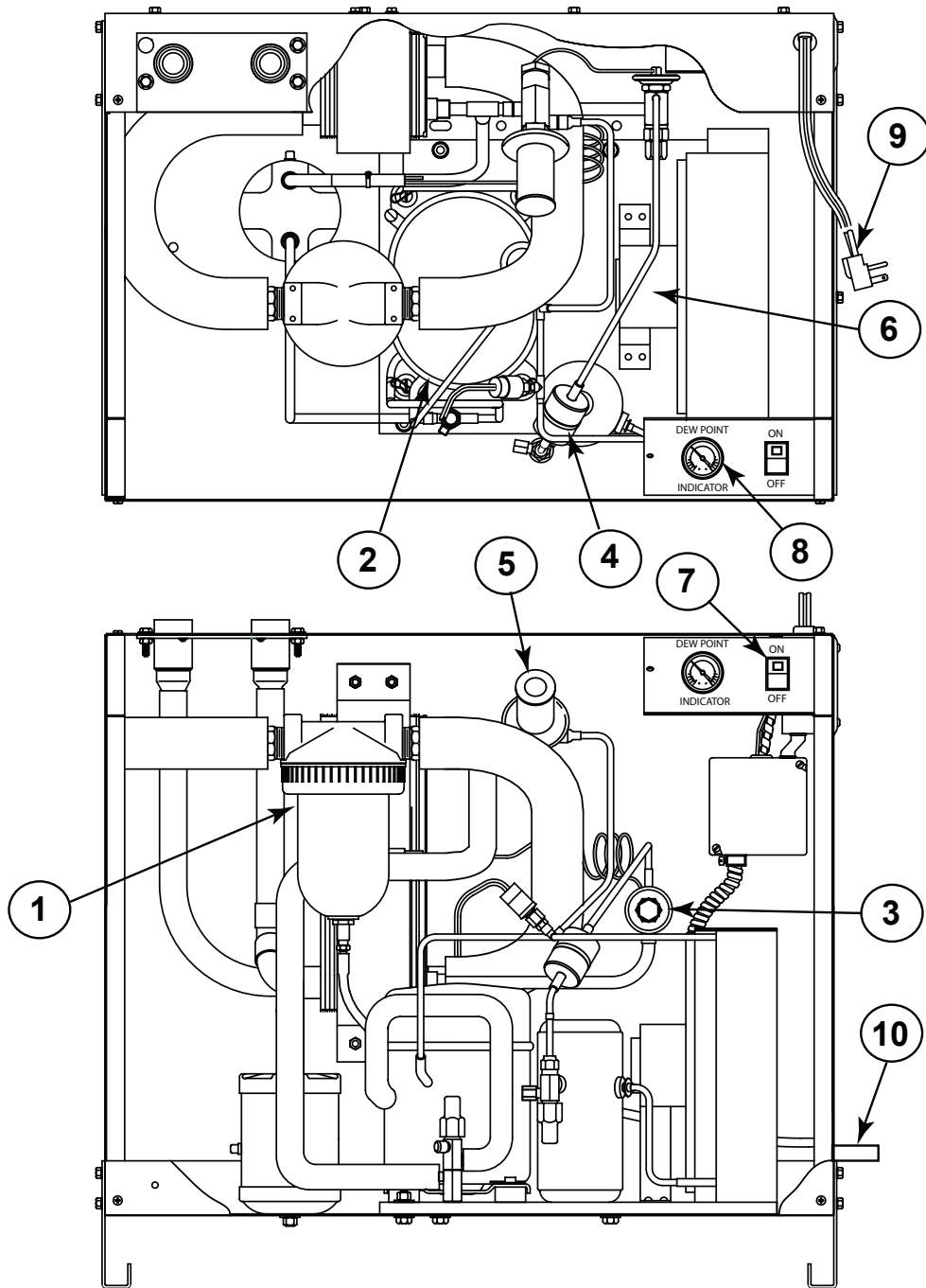

- 1) **Separator**
- 2) **Compressor**
- 3) **Expansion/Control Valve**
- 4) **Refrigerant Filter**
- 5) **Hot Gas Valve**
- 6) **Fan Motor**
- 7) **Power On Light/Switch**
- 8) **Dew Point Indicator**
- 9) **Power Cord**
- 10) **Drain Line**

## Receiving and inspection

Arrow Dryers are carefully prepared for shipment at the factory to protect them from damage in transit. Dryers are shipped F.O.B. factory. Immediately upon arrival, check the dryer for possible damage. **If damage is found, report it to the carrier and file a damage claim.**

Check the suction pressure gauge. If the suction pressure gauge reads zero, it indicates a possible refrigerant leak. Notify your dealer immediately.

Be sure you have the right dryer. Check the nameplate for voltage and amperage

## How the Air Dryer Works

Compressed air enters the inlet and passes through the air-to-air heat exchanger where the air is partially cooled by the exiting cold air. Next, the air passes through a refrigerant-to-air heat exchanger where it is cooled to near the freezing point of water. As the air is cooled, it loses the capacity to hold water vapor. The water vapor condenses into water droplets and drains to the separator. Passing through the separator, air flow slows down and causes more water to condense and collect in the bottom of the separator bowl. The water is exhausted by the electronic timer drain.

The compressed air, now at a pressure dew point of 35°F, leaves the dryer through the air-to-air heat exchanger where it is heated by the incoming air.

## Location and Installation

Locate the dryer indoors in a protected area where ambient temperature will range between 45°F and 100°F. Dryers are usually located near the compressor. Do not cycle the dryer with the compressor. If an aftercooler is used after the compressor, install the dryer downstream of the aftercooler and receiver (see figure 2). Install the dryer so that there is sufficient room around it to permit circulation of air through the refrigeration condensing unit. Allow for easy access into the dryer through the cover panel.

Check the nameplate for voltage and amperage. The dryer is furnished with a 6 foot electrical cord for connection to a grounded outlet.

Be sure that the compressor air passes through the dryer in the proper direction. Connect the compressed air lines to the inlet and outlet connection as marked on the cabinet. Connect the air lines with standard pipe fittings.

The mechanical separator has a isolation valve and strainer to prevent debris from blocking the electronic timer drain. The electronic timer drain is hard mounted and wired inside the dryer, but is accessible from the left side of the dryer.

It is recommended that a bypass line is piped around the dryer. Shutoff valves should be installed at both inlet and outlet, with another valve in the bypass line. This complies with O.S.H.A. lockout regulations and permits the dryer to be removed from the system or serviced without turning off the air supply.

## Typical Compressed Air Systems

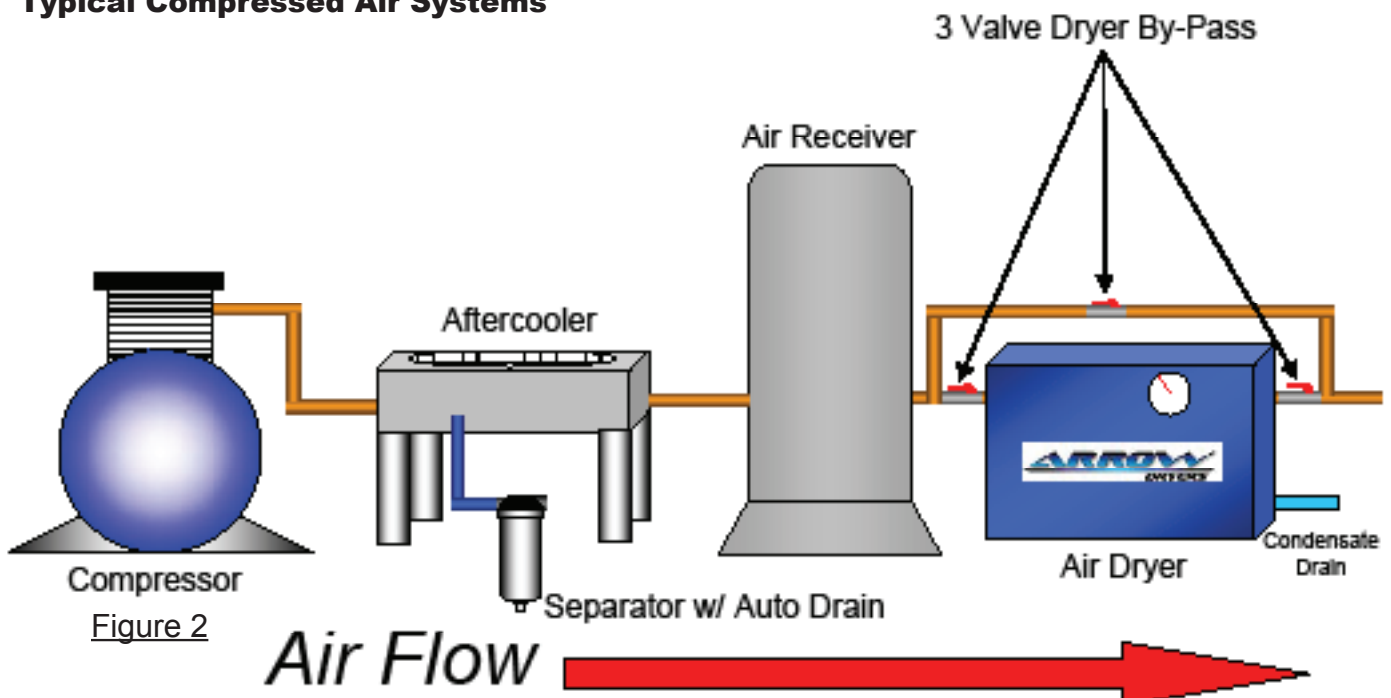
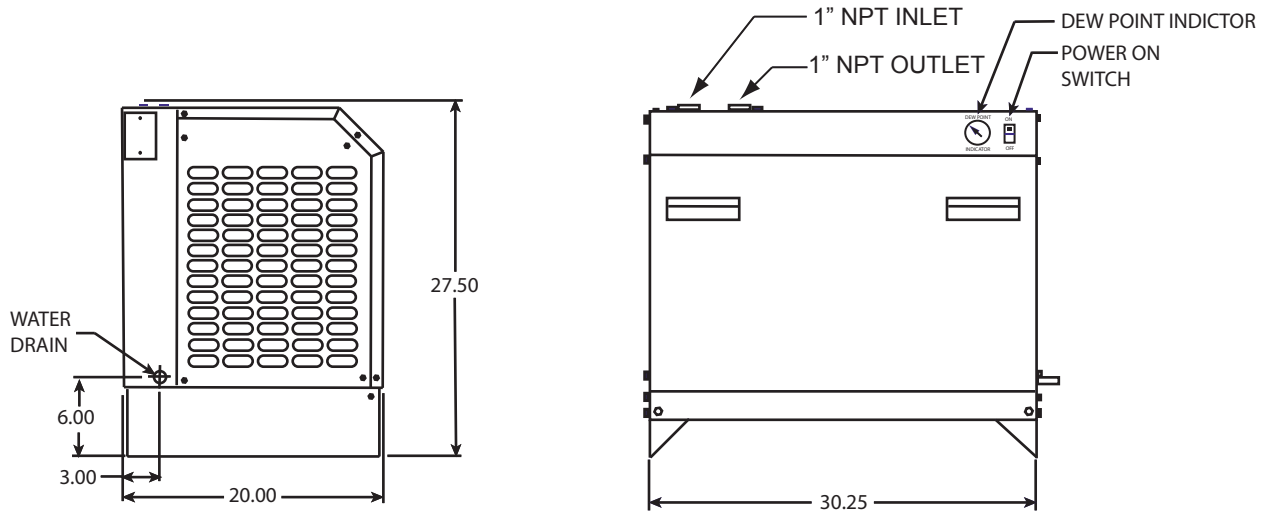
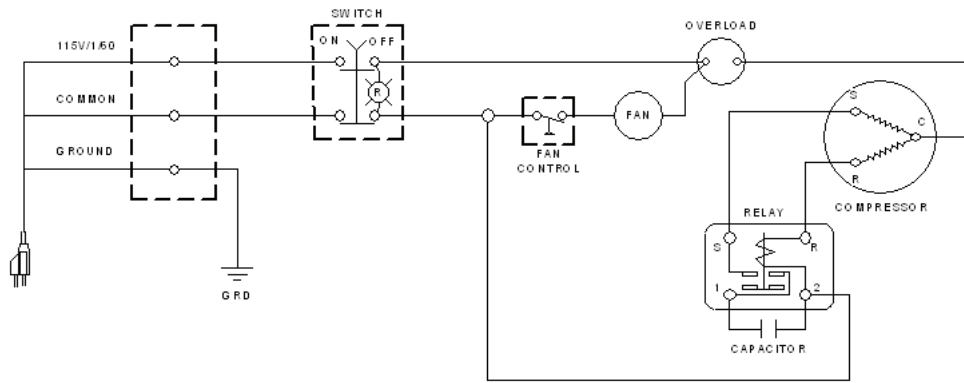

Figure 2

**Dimensions**  
**F-75 Air Dryer**



**F-75 Wiring Diagram  
115 V CSIR**



**F-75 Wiring Diagram  
230 V CSIR**

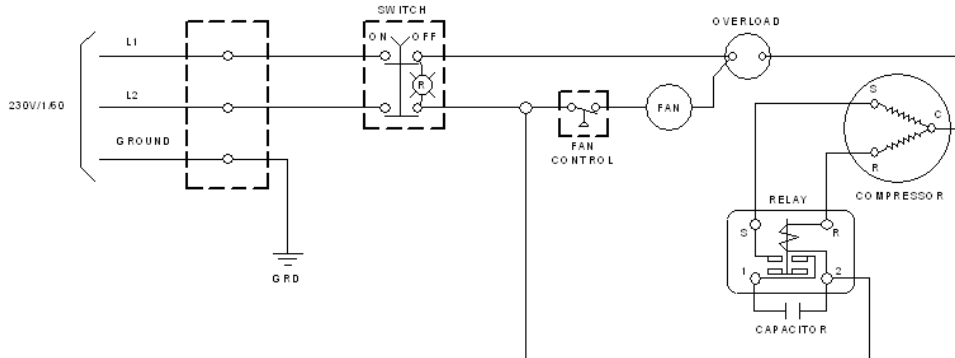

**Specifications**

Model No.	Power Supply	Capacity SCFM @ 100 PSIG	Dimensions (Inches)			Air Line Conn. FPT	Drain Line Conn. O.D.	H.P.	Refrig Charge* R-134A	Net Wt. Lbs.	Max. Press. PSI	Full Load AMP	L.R. AMP	GPM* 85°F In, 95°F Out
			Length	Height	Width									
F-75-1	115/1/60	75	30	27.5	20	1"	3/8"	1/3	2.8 Lbs.	163	250	7.2	29.8	1.2
F-75-2	230/1/60	75	30	27.5	20	1"	3/8"	1/3	2.8 Lbs.	163	250	3.4	17.3	1.2

CFC-Free R-134A

NOTE: The air leaving the dryer is reheated to 25°F below the inlet air temperature  
\* Maximum water flow for water cooled units only.

## Design Conditions

**The Dryer must not be cycled with the air compressor.** The dryer is non-cycle and is designed to run continuously (even under light loads). If the compressed air system remains pressurized and the air compressor cycles off and on to maintain line pressure, the dryer should remain in operation to keep the air lines dry.

**Air Flow SCFM:** The rated air flow (SCFM) of the dryer is designed for 100 PSIG. Above the rated air flow, the dew point will rise and moist air may reappear downstream. The dryer may cycle off and on under excessive load and cause compressor damage.

**Inlet Air Temperature:** The dryer will function normally up to 100°F. Above this temperature, the dryer capacity will fall off. Inlet air temperature should be controlled so that it does not exceed 100°F.

**Line Pressure:** The maximum design pressure is 250 PSIG.

**Ambient Air Temperature:** Locate the dryer indoors in a protected area where the ambient temperature will range between 45°F and 100°F. Note: Above an ambient temperature of 100°F the refrigerant will rise until the dryer shuts down. Several off and on cycles under these conditions will damage the compressor.

**Automatic Expansion Valve:** The automatic expansion valve regulates the refrigerant suction pressure. The expansion valve is factory set between 33 and 36 PSIG.

## Start UP

- 1) On initial start-up of system check electrical connections to the dryer, as well as the air piping, so inlet and outlet piping are connected to correct ports.
- 2) Check panel mounted Dew Point Indicator gauge before starting. The indicator must read above the green area and into the high red section.
- 3) When ready to operate the compressed air system, the dryer should be started before air compressor is started.
- 4) When closing the start switch the indicator light on the front panel of dryer will show there is power to the refrigeration compressor. The dew point indicator will slowly drop and hold within the green area the gauge.
- 5) When pressure has dropped to this level the air compressor can be started and air flow can begin.

**NOTE:** All dryer models are designed to operate without compressed air load in order to pre-cool the heat exchanger surface.

**NOTE:** Operation of dryer is automatic and continuous. Refrigerant compressor does not cycle off and on. Discharge of condensate through drain is automatic.

## To Stop

To stop the unit turn start-stop switch to off position.

**IMPORTANT:** IF IT IS NECESSARY TO PROTECT THE AIR SYSTEM DURING NORMAL SHUT-DOWN THE INLET SHUT-OFF VALVE TO THE DRYER SHOULD BE CLOSED TO PREVENT WET AIR FROM ENTERING AIR SYSTEM.

## How to Make Minor Refrigerant Suction Pressure Adjustments

- 1) Keep the dryer running **under no load** and turn off or bypass the compressed air.
- 2) Remove the dryer cover and locate the control valve (See Figure 3).
- 3) Remove cap. With 5/16" allen wrench a turn clockwise to increase or counterclockwise to decrease the suction pressure (1/4 turn will normally be enough). Wait 3 to 4 minutes for the suction pressure to settle. Repeat if needed. Replace cap when adjustments are completed.

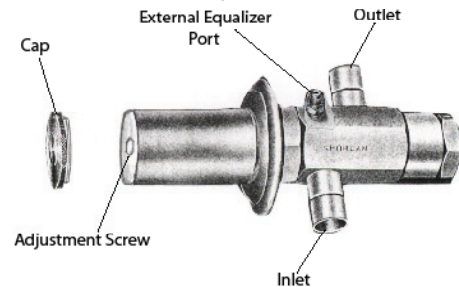

Figure 3

## Maintenance and Care

**NOTE:** Refrigerant air dryers require relatively little maintenance if they are used accordance with the installation and operating instructions.

### Cleaning Fin Surface

**NOTE:** These are air cooled refrigeration systems and depend upon cooling air drawn from the area around the dryer for efficient operation.

1. Inspect the fin surface of the condenser regularly and keep it free of dust, lint or paper.

**NOTE:** A vacuum cleaner or low pressure air hose can be used for regular and normal maintenance of the fin surface.

2. Machine shop applications with oil vapor in the room air may require cleaning with fin surface cleaners available from refrigerant supply houses.

### Cleaning Timer Drain and Filter Element

**All models** (see Figure 5) have a timer operated drain attached to the bottom of separator bowl.

1. Accumulation of compressor oil in the bowl of the separator as well as the sintered bronze element is possible. Both should be cleaned periodically.
2. Remove foam insulator from separator head.
3. Use a strap or chain wrench to remove the water separator bowl.
4. Drop bowl and remove completely.
5. Clean sintered bronze element with kerosene.
6. Reassemble in reverse order.
7. Close strainer ball valve and relieve drain pressure by pressing "test" button on timer rain. Remove strainer screen from ball valve assembly located below separator. Clean with compressed air or pressurized water.
8. Test drain by depressing the "Test" button on the timer. If valve fails to open, or does not seal when closed, close the isolation valve (located near the strainer) and clean or replace the valve.

## Model F-75

Figure 4

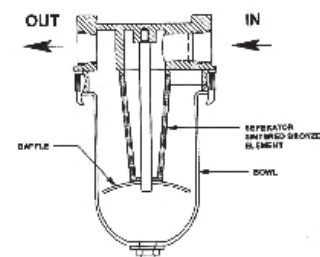

Symptom	TROUBLESHOOTING CHART Possible Causes(s)	Corrective Action
Unit will not run.	<ol style="list-style-type: none"> <li>1. No Power.</li> <li>2. Internal compressor overload.</li> </ol>	<ol style="list-style-type: none"> <li>1. Correct power supply, fuses, circuit breaker.</li> <li>2. Feel the temperature of the compressor and allow to cool off if hot. Observe the fan motor. Have the motor checked if it does not run. Clean the condenser.</li> </ol>
Dew Point Indicator Red Area High	<ol style="list-style-type: none"> <li>1. Internal compressor overload.</li> <li>2. High ambient temperature.</li> </ol>	<ol style="list-style-type: none"> <li>1. Check for air overload. Check inlet air temperature. Check operation of fan motor.</li> <li>2. Check room temperature and hold between 45°F and 100°F.</li> </ol>
Dew Point Indicator Red Area Low	<ol style="list-style-type: none"> <li>1. Low refrigerant charge.</li> <li>2. Low ambient temperature.</li> <li>3. Low hot gas valve setting.</li> </ol>	<ol style="list-style-type: none"> <li>1. Have qualified refrigeration service technician check out dryer or call factory.</li> <li>2. Relocate dryer to heated area between 45°F and 100°F</li> <li>3. Re-adjust hot gas valve to the green area on the dew point indicator gauge. (See minor pressure adjustments)</li> </ol>
High pressure drop	<ol style="list-style-type: none"> <li>1. High air flow.</li> <li>2. Drain valve not discharging.</li> <li>3. Freezing moisture in evaporator.</li> <li>4. Plugged separator element or drain.</li> </ol>	<ol style="list-style-type: none"> <li>1. Air flow above rated flow of dryer.</li> <li>2. Manually blow down drain until water flow stops. Clean drain.</li> <li>3. Re-adjust hot gas valve to the green area on the dew point indicator gauge. (See minor pressure adjustments)</li> <li>4. Clean or replace.</li> </ol>
Water downstream of dryer	<ol style="list-style-type: none"> <li>1. Compressed air is flowing through dryer before it is turned on.</li> <li>2. Dirty separator element or drain.</li> <li>3. Overload dryer above air flow capacity.</li> <li>4. High suction pressure.</li> <li>5. Low outlet air pressure.</li> <li>6. Low refrigerant charge.</li> </ol>	<ol style="list-style-type: none"> <li>1. Dryer must be operating 5-10 minutes before compressed air load.</li> <li>2. Disassemble and clean.</li> <li>3. Reduce air load to dryer specifications.*</li> <li>4. Inlet air temperature too hot.</li> <li>5. Freezing of water, adjust suction pressure.*</li> <li>6. Contact service technician to leak check.</li> </ol>

**NOTE:** Check or repairs of the refrigeration system must be done by a qualified refrigeration service technician with the required gauges and other equipment.

\*All adjustments must be made under no compressed air load.

**If Trouble Starts**

If the dryer cycles off and on for any reason TURN OFF THE DRYER. Call the factory for instructions, **Check or repairs of the refrigeration systems must be made by a qualified refrigeration service technician.** Before calling the factory for instructions, have the following data to report.

Model No. \_\_\_\_\_

Serial No. \_\_\_\_\_

Refrigeration Suction Pressure. \_\_\_\_\_

**REPLACEMENT PARTS**

<b>Model</b>	<b>F-75-1</b>	<b>F75-2</b>
Voltage	115/1/60	230/1/60
Compressor Make	Copeland R-134A	Copeland R-134A
<b>Separator/ Drain Assembly</b>	<b>PART NUMBER</b>	<b>PART NUMBER</b>
Separator	FK329-S1	FK329-S1
Separator Bowl	3110-S1-8	3110-S1-8
Repair Kit	RFK329	RFK329
Element Kit	EKF329	EKF329
Electronic Timer Drain	27901	27902
<b>Refrigeration System</b>		
Condensing Unit	14618	14619
Compressor	14774	14775
Expansion Valve	14571	14571
Hot Gas Bypass Valve	14516	14516
Refrigerant Filter	14576	14576
<b>Electrical</b>		
Fan Motor	95933	95936
Fan Blade	14776	14776
Fan Switch	91639	91639
Power On Light/Switch	97846	97846
Power Cord	91698	-----
<b>Gauges</b>		
Dew Point Indicator	14765	14765
<b>Cabinet Panels</b>		
Base Panel	14640	14640
Cover Panel	14642	14642
Back Panel	14641	14641
End Panel Right Side Vented	14649	14649
End Panel Left Side Vented	14643	14643

**ORDER REPLACEMENT PARTS  
BY CALLING  
(877) 640-8300**

Please provide following information:

- Model Number
- Serial Number (if any)
- Part Description and Number

Address parts correspondence to:

ARROW DRYERS  
745 Clark Ave.  
Bristol, CT 06010

**WARRANTY POLICY**

**When used under the conditions recommended by the manufacturer, Arrow Dryers, this model is warranted to be free from defects in material and workmanship for a period of twenty-four (24) months from date of receipt, not to exceed thirty (30) months from the factory ship date, provided Arrow is furnished the customer's name, address, and date of shipment information**

**These units will utilize either a braze plate or modular type heat exchanger which will be warranted for five (5) years. This warranty is limited to the replacement of the heat exchangers, F.O.B. Factory, and subject to the same restrictions as outlined below concerning misuse, abuse or accident. The electronic timer drain carries a 90-day warranty.**

**This warranty will apply to equipment installed, operated and maintained in accordance with the procedures and recommendations as outlined in the owner's manual published by Arrow Dryers.**

**During the life of this warranty, Arrow Dryers will repair or replace (at Arrow Dryers' option) any defective part or assembly, free of charge, F.O.B. its plant if such defect occurred in normal service and was not due to apparent misuse, abuse or accident.**

**Any warranty service performed in the field must be authorized by Arrow Dryers, Unauthorized service voids the warranty and any resulting charge will not be paid by Arrow Dryers.**

**Arrow Dryers makes no other warranties or guarantees, expressed or implied. The merchantability of the components is expressly excluded. The manufacturer assumes no liability for indirect or consequential damages.**

